

DMSB Circuit Regulations 2022 - Appendix 2

Particularities for the Nürburgring Nordschleife as on *30/11/2021* – changes are printed in *italics*

The regulations of Appendix 2 to the DMSB Circuit Regulations apply as a supplement to the DMSB Circuit Regulations for Particularities of series / events / competitions at the Nürburgring Nordschleife (Nürburgring Langstrecken-Serie *NLS*, ADAC Qualification Race 24h-Race, ADAC Total 24h-Race, Youngtimer Trophy, FHR- Racing series, RCN circuit race, etc.).

This list of series / events / competitions on the Nürburgring Nordschleife is not exhaustive and can be supplemented by the DMSB at any time.

In addition, the series regulations and supplementary regulations of the relevant series / race events / competitions apply.

Art. 1 Admission requirements for participants

All participants in automobile sport events taking place at the Nürburgring Nordschleife must have reached the age of 18 years. Moreover, the specific licence regulations of the DMSB Appendix 1 and the specific licence regulations published in the corresponding Series- and/or Event Supplementary Regulations must be respected.

DMSB Permit Nordschleife (DPN)

The DMSB Permit Nordschleife (DPN) is basically mandatory for all participants Competitor/Driver licence of the DMSB or of another ASN affiliated to the FIA) in all DMSB approved series / events / competitions taking place at the Nürburgring Nordschleife.

The conditions for the issue are stipulated in the DMSB Licence Regulations appendix 1. Three grades of the DPN are issued:

Grade A: Valid for vehicles with a maximum power/weight ratio of 4.2 kg/HP (5.71 kg/kW)*

Grade B: Valid for vehicles with a power/weight ratio of > 4.2 kg/HP (5.71 kg/kW)*

Grade C: Valid for Youngtimer Trophy, FHR-Series as well as the RCN-Circuit Race Schwedenkreuz according to the series regulations without categorization.

*Approximate values; the exact classification of vehicles (in classes pursuant to the Supplementary Regulations of the corresponding series or event) is approved by the DMSB and specified in Art. 8 (Table "Division of vehicle categories A and B and C for the DPN").

For all further or new races/series, the vehicles will basically be classified on basis of the aforementioned power-to-weight ratio. The organiser / series organiser shall publish the classification in the Supplementary Event Regulations / Series Regulations. The DMSB reserves the right to define additional conditions for the participation.

Art. 2 Admission requirements for Vehicles/ Design Requirements

The following points must be respected for all vehicles to be eligible for competing at the Nürburgring Nordschleife:

- (1) Only touring cars and GT cars with closed body and solid roof or hardtop (no convertibles) as well as the vehicle groups specified in the DMSB track licence are eligible.
- (2) Sports cars, formula cars as well as cars with open wheels are not eligible.
Moreover, vehicles with tube frame chassis are not eligible; exceptions:

- a) Vehicles of groups 24h Special (SP) and SP-X that have been approved by the ADAC Nordrhein/VLN Technical Commission in agreement with the DMSB,
 - b) GT3 vehicles with FIA approval and/or GT4 vehicles with RACB/KNAF approval,
 - c) Appendix K vehicles with Historic Technical Passport (HTP).
- (3) The vehicles must have mudguards that are integrated into the bodywork. Vehicles equipped with steering mudguards (as for example Donkervoort, Lotus Super 7, or similar) are not permitted.
- (4) The vehicle must furthermore have a solid bodywork between the front and the rear wheels (breaking-in protection). The maximum dimension X is 150 mm (see drawing 1).

Drawing 1:

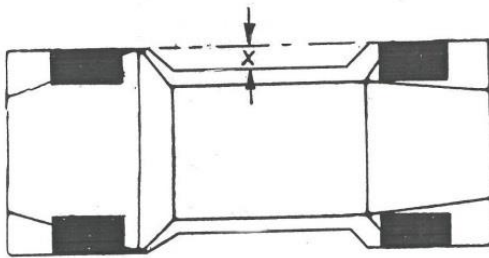

- (5) The height of the competition car, measured at the roof, must be at least 1100 mm.
- (6) In general, tires are allowed for all categories of vehicles, in accordance with the "DMSB Approval List tires Nürburgring Nordschleife". Except cars of class SP-X and SP-Pro and all cars with GT3 – homologation from 2010 on. For vehicle categories for which no commercially available tires according to the "DMSB Approval List tires Nürburgring Nordschleife" are prescribed (SP-X and SP-Pro and all cars with GT3 – homologation from 2010) the DMSB-regulations „Musterreifen-Prozedere for [NLS](#) and 24h-Race 2022“ for the Nürburgring Langstrecken-Serie [NLS](#), ADAC Total Zurich 24h Race including ADAC Qualification Race 24h Race, is mandatory.
- (7) To be eligible for participation at the Nürburgring Nordschleife, all vehicles (including historic) must at least be equipped with a safety device according to the Appendix J 1993, Article 253.8 drawing 1 (roll bar), with towing eyes, a 2 kg manual fire extinguisher, a circuit breaker and safety belts. An FIA approved FT3/FT5 safety tank is mandatory for vehicles with Diesel engines.

Art. 2.1 DMSB special provisions for vehicle classes SP 9 (FIA-GT3), SP-PRO and SP-X

In addition, the DMSB special provisions for vehicle classes SP 9 (FIA-GT3), SP-PRO and SP-X regards engine performance, Traction Control System, minimum height, rear wing width / position, aerodynamics, etc. are mandatory.

(1) Minimum height for vehicles of category SP9 (FIA-GT3), SP-X, SP-Pro

At any time during the event, it must be possible to move a role with the dimensions 300mm (width) x 70 mm (diameter) freely under the vehicle. The check will be made in the designated areas of the organizer.

For the check, a team member may adjust the tyre pressure of all four wheels onto 1.8 bar. If the tyre pressure is adjusted, the adjusted pressure must be identical for all tyres. A correction of the tyre pressure will only be applied if, at the moment of the measurement, the tyre pressure of one or several tyres was determined to be below 1.8 bar. Only the measuring value of the official organiser's manometer will be used for the measurement of the tyre pressure.

The check will be carried out with the car in its actual condition, with the tyres fitted at the moment of the check, with the actual fuel amount inside the car at the moment of the check and with the driver.

The following provisions generally apply in addition in relation to the check of the minimum ride height during a post-event scrutineering:

- Upon the instruction of a scrutineer, the tyre pressure of all four tyres must be adjusted by a team member onto 1.8 bar.
- To determine the tyre pressure, only the measured value of the official manometer of the organiser will be used,
- If a vehicle fitted with rain tyres is placed in the Parc Fermé or is subject to a post-event check, this vehicle must be fitted with new slick tyres if a check of the minimum ride height is scheduled to be carried out.
- Upon the instruction of a scrutineer, the tyre pressure for all four tyres must be adjusted by a team member onto 1.8 bar.

The organiser reserves the right to carry out the test at any time with the driver who has last driven the corresponding car.

The check will be carried out on the measuring surface defined by the DMSB and communicated in the Event Supplementary Regulations or in a Bulletin.

Any systems for changing the vehicle height automatically while driving or at a standstill of the vehicle are prohibited. Exceptions are made by the ADAC Nordrhein/VLN Technical Committee.

(2) Anti Lift System

Vehicles of categories SP9 (FIA-GT3) and SP-X must be equipped with an electronic anti-lift system. This anti-lift system must be understood as an extension of existing traction control system.

The construction of these systems is open for the vehicle manufacturers in generally.

A documentation of the operation of these systems must be submitted to the organizer by the manufacturer before a vehicle use on the Nürburgring Nordschleife.

A release takes place after consultation with the DMSB. Responsible for safe operation of the anti-lift system is the homologation owner or vehicle manufacturer, in principle. Exceptions are made by the ADAC Nordrhein/VLN Technical Committee.

(3) Modified aerodynamics – Rear wing width/position

Applicable for vehicles of classes SP9 (FIA-GT3) from homologation date 01.01.2012 incl. EVO extensions (evolution)

The admissible overall width of the rear wing pursuant to the homologation will optionally be reduced by 100 mm at the outsides (at the position of the wing end plates in direction vehicle longitudinal axis) or the position of the rear wing is moved by 100 mm in direction of the positive vehicle x-axis. The corresponding manufacturer has the option to apply any proportionate combination of reduction in width/change of position within the total of 100 mm. It is for example permitted to reduce the width by 50 mm in combination with the movement of the rear wing by 50 mm in direction positive x-axis (towards the vehicle front). The wing profile must however always comply with the homologation. The addition of non-homologated gurney profiles is not authorized.

The homologation owner must submit a corresponding Data Sheet to the ADAC Nordrhein/VLN Technical Committee to apply for the reduction in width/change of position. The Data Sheet must specify the geometry of wing supports as well as the wing width and rear wing position. The modified aerodynamics must be uniformly applied to all cars of a manufacturer with the same FIA homologation number. The application of the wing position tolerances specified in the corresponding FIA homologation form is accepted. A non-homologated elevation of the rear wing or a non-homologated setting angle is not authorised.

EVO Extensions, without any influence of performance/BoP could be excluded from the aforesaid rule by the ADAC Nordrhein/VLN Technical Committee application, after application.

Note:

The above mentioned provisions regarding the rear wing width and/or position deviating from the corresponding FIA homologation can only be applied for and/or documented by the homologation owner. The modifications will be recorded in the vehicle-specific Data Sheets after approval by the ADAC Nordrhein/VLN Technical Committee and become thus binding for all cars with the corresponding FIA homologation number.

The organiser reserves the right to classify vehicles of class SP-X also according to the above provisions for the classes SP9 or SP9 – LG.

(4) Front aerodynamics

Applicable for vehicles of classes SP9 (FIA-GT3) from homologation date 01.01.2012 incl. EVO extensions

No modifications with regard to the homologation may be applied on the front part and on the front diffuser.

Exception: To re-establish the aerobalance due to the reduced downforce on the rear of the vehicle (see 7.3), the flics may be reduced in their surface by 30%. If 2 flics on each side are admitted, one flic may be removed on each side.

If this step is not sufficient, it is permitted to add inserts into the front diffuser. The attachment method is free. It must at all times be possible to re-establish the original form of the homologated diffuser. The manufacturer must submit a Data Sheet to the ADAC Nordrhein/VLN Technical Committee to apply for an approval of these adjustments. The Data Sheet must specify the measuring results from wind channel tests as well as drawings of the modified diffuser/flic geometry.

The Data Sheet must also specify the geometry of the insert/s as well as the dimensions, position and fixations. The modified aerodynamics must be uniformly applied to all cars of a manufacturer with the same FIA homologation number.

The final decision on the admission shall be taken by the ADAC Nordrhein/VLN Technical Committee. The aerobalance may be checked by route data which must be supplied by the manufacturer.

(5) Refuelling

Applicable for vehicles of categories SP9 (FIA-GT3), SP-X, SP-Pro

A two-stage safety non-return flap valve must be used for refuelling the car during the event (e.g. Manthey-TZN Capless 2-3).

For safety reasons, an additional fuel-tight closure (valve/sealing cap) must seal the exterior filler opening (see drawing 2).

Drawing 2:

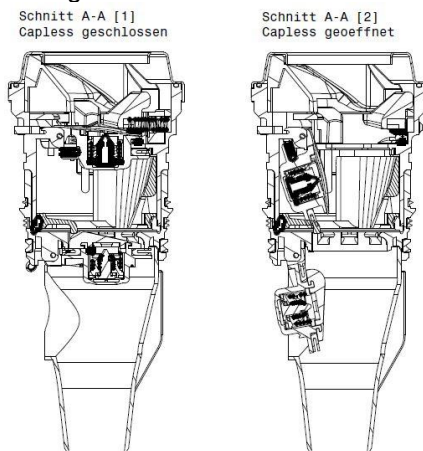

Functional principle

The safety flap valve in form of a sample part and drawing, including functional description, must be submitted to the ADAC Nordrhein/VLN Technical Committee for approval.

No containers (e.g. fuel cans) may be used for the refuelling of the cars. Ventilation valves, if present, may not be opened manually. Ventilation valves may furthermore be sealed at scrutineering.

- (6) An FIA ventilation valve/roll-over-valve in compliance with Art. 253 14.2 Appendix J and homologated for the corresponding car model must be installed to the vehicle fuel system directly to the tank.

Two additional DMSB approved ventilation valves (e.g. Sobek) must furthermore be installed. A schematic diagram or CAD data if the tank system with ventilation must be submitted to the ADAC Nordrhein/VLN Technical Committee for approval.

If the tank valve is positioned directly above the exhaust system on the car, a fire-proof temporary cover with a suitable dimension must be provided. This device must be fixed with Velcro strips or magnetic lock throughout the duration of the refuelling procedure so that any fuel on the exhaust system cannot inflame in the case of a leakage.

DMSB has the right (technical and athletic) to amend regulations to ensure safety at all times.

Art. 3 Starting grid / Start

The vehicles can be set up in different starting groups and will be started rolling in accordance with the DMSB track license and the special regulations, supplementary regulations of the respective racing series or event.

In addition the provisions of Art. 7 of the DMSB Circuit Regulations must be observed.

Art. 4 Intervention Car on the Nürburgring Nordschleife

(1) General

At races, events / competitions on the Nürburgring Nordschleife one or more intervention cars can be operate. Intervention Cars ensure local and temporary limited risk situations and / or accident sites on the Nürburgring Nordschleife. An intervention car is equipped with one or more yellow / orange flashing lights on the roof and marked "Intervention Car". The intervention Cars drive on with yellow / orange flashing lights on the track.

(2) Driving Intervention Car secures slow vehicles ahead

Yellow / orange flashing light on - marshals waves yellow flag.

The Intervention Car accompanies and protects slow vehicles in front (ambulance, tow truck, fire brigade, track repair vehicles, etc.).

- The intervention car and the slow vehicles ahead may be overhauled
- There is an overtaking ban for the participants among themselves,
- There is no speed limit,
- the speed must be adjusted during overtaking so as not to endanger the intervention car and the slow vehicles ahead.

(3) Standing Intervention Car

Yellow / orange flashing light on - marshals waves double yellow flags or show "Code 60" flag/board.

The Intervention Car ensures a dangerous situation and / or accident site. Rescue and recovery forces can work on or near the track and the track can be partially or completely blocked.

- reduce speed (maximum 120 km / h or 60 km / h),
- be ready to stop,
- there is no overtaking allowed.

Art. 5 Flag Signals - applicable by all races at the Nürburgring Nordschleife

Yellow flashing lights (FlashLights) on the Nürburgring Nordschleife have the meaning of a single waved yellow flag.

If emergency cars of the DMSB Staffel, E-Unit, medical cars or intervention cars are driving on the track, the safety marshals will show the waved white flag.

As long as a vehicle of the DMSB Staffel, E-Unit, medical car or intervention car is stationary for rescue or recovery operations, the safety marshals will show the double waved yellow flag or show "Code 60" flag/board. .

As long as a vehicle of the DMSB Staffel is towing a car as well as during emergency ambulances (RTW) and fire-fighting vehicles were on track, the safety marshals will show the yellow waved flag in the area of the moving towing cars, emergency ambulances (RTW) and fire-fighting vehicles.

- The towing cars, emergency ambulances (RTW) and fire-fighting vehicles may be overhauled
- there is an overtaking ban for the participants among themselves,
- there is no speed limit (except *double yellow flags* or "Code 60" flag/board.),
- the speed must be adjusted during overtaking so as not to endanger the towing cars and the slow vehicles ahead, the emergency ambulances (RTW) and fire-fighting vehicles.

Furthermore Art. 8 is applicable.

Art. 6

List of penalties Nürburgring Nordschleife for series/events in which the DPN is mandatory

Any speeding will be established by use of the official measuring system prescribed by the organiser (e.g. GPS data).

Art. 6.1 Speeding in the pit lane

Maximum permitted speed in the Nürburgring Nordschleife pit lane is 60 km/h at any time of an event, unless otherwise specified by the DMSB approved series or event regulations.

(1) **Speeding in the pit lane during free practice, warm up, qualifying will incur the following penalties** by the clerk of the course / race director:

- fine pursuant to Art. 15 (4) DMSB Circuit Regulations,
- time penalty,
- non-evaluation (laps, lap times, results),
- Change of starting position / retransfer on the grid.

Maximum of 2 infringements per driver, in case of additional infringements, a report will be submitted to the Stewards.

(2) **Speeding in the pit lane during the race will incur the following penalties** by the clerk of the course / race director:

Level	Over the speed limit	Penalty (Race duration acc. Suppl. Regs.)	Number of infringements
1	Up to 10 km/h	30 sec. time penalty (Stop-and-Go)	Maximum 2 infringements per driver, in case of additional infringements, a report will be submitted to the Stewards.
2	11 km/h - 20 km/h	60 sec. time penalty (Stop-and-Go)	
3	> 20 km/h	At the discretion of the Stewards	

When the max. number of infringements is exceeded, a penalty (disqualification via black flag) will be applied by the Stewards.

Any number of infringements regarding the maximum permitted speed in the pit lane in the timed practice will not be added to the maximum number of infringements in the race. All penalties will remain unaffected hereof.

Art. 6.2 Non-respect of flag signals

- (1) **Non-respect of double waved yellow flags or of Code 60 flags/boards in the free practice, warm up, qualifying** will be penalised throughout the clerk of the course / race director / Stewards as follows:

Level	Speeding	Penalty (Race duration acc. to Suppl. Reg.) applied by the clerk of the course/ Race Director / Stewards	DMSB penalty points register
1	Up to 20 km/h	Start from the last position of the starting group	None
2	21 - 40 km/h	Start from the pit lane at the end of the starting group in the race	1 point
3	41 - 60 km/h	Start from the pit lane at the end of the starting group in the race Additionally: 120 seconds time penalty (stop-and-go) in the race	2 points
4*	> 60 km/h	Start from the pit lane at the end of the starting group to the race Additionally: 180 seconds time penalty (stop-and-go) in the race And immediate disqualification of the corresponding driver + withdrawal of the DPN of the driver concerned	Report to the DMSB

Maximum 1 infringement per team regarding levels 1, 2, 3; in case of additional infringements, a report will be submitted to the Stewards.

*A penalty will be imposed by the Stewards for any Infringements of level 4. If an additional driver of the corresponding teams commits an additional infringement of level 4 at the same event, the following applies: Black flag + withdrawal of the DPN of the corresponding driver as well as disqualification for the corresponding team (Definition Team = the drivers entered for that vehicle).

(2) **Non-respect of double waved yellow flags or of Code 60 flags/boards in the race** will penalised throughout the clerk of the course / race director / Stewards as follows:

Level	Speeding	Penalty applied by the clerk of the course / Race Director / Stewards at a race duration of (acc. To Suppl. Reg.):				Maximum no. of infringements	DMSB-Penalty register
		3h	4h	6h	24h		
1	Up to 20 km/h	40 sec. Time penalty	45 sec. Time penalty	55 sec. Time penalty	1 min 32 sec. Time penalty	Max. 2 infringements (24h Race: max. 3 infringements) per driver, in case of additional infringements, a report will be submitted to the Stewards which will result in the Black Flag and the Disqualification of the corresponding driver.	None
2	21 - 40 km/h	130 sec. Time penalty	150 sec. Time penalty	200 sec. Time penalty	3 min 32 sec. Time penalty		1 point
3	41 - 60 km/h	250 sec. Time penalty	270 sec. Time penalty	300 sec. Time penalty	5 min 32 sec. Time penalty		2 points
4*	> 60 km/h	300 sec. Time penalty	320 sec. Time penalty	350 sec. Time penalty	7 min 32 sec. Time penalty	disqualification of the driver concerned + withdrawal of the DPN of the driver concerned	Report to the DMSB

*A penalty will be imposed by the Stewards for any Infringements of level 4. If an additional driver of the corresponding teams commits an additional infringement of level 4 at the same event, the following applies: Black flag + withdrawal of the DPN of the corresponding driver as well as disqualification for the corresponding team (Definition Team = the drivers entered for that vehicle).

Art. 6.3 DMSB Penalty Register

The DMSB runs a "DMSB Penalty Register" for DPN-compulsory events held at the Nürburgring Nordschleife. The penalties catalog for the disrespect of the maximum speed in the pit lane, roughly unsportsmanlike or participant-endangering behavior as well as for the disrespect of flag signs.

The penalty register is administrated by the DMSB. The total of 3 points or any one infringement of level 4 results in the provisional withdrawal of the DPN.

Irrespective of the number of points in the penalty register or of the withdrawal of the DPN, a proceeding under sporting law may be initiated.

In addition, the DPN may be withheld by the stewards of the event of grossly unsportsmanlike or participant-threatening behavior and sent to the DMSB for further examination.

Penalty points will lapse at the end of the calendar year in which the infringements was committed, with the exception of penalty points which have been applied within the framework of the last *NLS* race as these will be carried over into the following year.

Art. 7 Time Penalties / Alternative Time Penalties

The location for taking a time penalty (Stop-and-Go) is specified in the corresponding Supplementary Regulations and / or communicated in the driver's briefing.

A time penalty may be combined with a pit stop, the procedures are specified in the corresponding Supplementary Regulations of the series or event.

Alternative time penalties may be applied if the time penalty cannot be taken during the running of the race (e.g. a time penalty issued towards the race end). The decision is at the discretion of the clerk of the course /race director.

Classification penalties issued during the timed practice may be applied at the next race.

Example:

In the case of a speeding infringement under double waved yellow flags in the timed practice, the penalty may, as an alternative to the drop of grid positions, be applied during the race. The decision is the responsibility of the clerk of the course / race director.

Art. 8

Code 60 – Provisions for all races (incl. RCN) at the Nürburgring Nordschleife

Supplement to Appendix 1 – DMSB Circuit Regulations: The following Flag-Signal-Regulations are introduced for all DMSB-approved races and performance tests at the Nürburgring Nordschleife:

- (1) From the double waved yellow flag the maximum speed for all participants is 120 km/h. The double waved yellow flags is shown as warning for a possible Code 60-zone.
- (2) If a hazardous situation or an accident exists which would requires the use of a Safety Car under Article 11 DMSB Circuit Regulations, a "Code 60" flag/board is shown on the affected marshal post. From the "Code 60" flag/board the maximum speed for all participants is 60 km/h.
- (3) The end of the double yellow flags is signaled at all involved post´s by a waved green flag. The speed limit can be lifted by the green flag or simply by a yellow flag. If a yellow flag is displayed, the competitors' overtaking ban will remain until the green flag.
- (4) The end of the "Code 60" - zone is signaled by a waved green, yellow or double yellow flag. The overtaking of the towing cars within a "Code 60" zone is allowed subject to the max. Speed of 60 km / h.

Any non-respect of the yellow flags/flag masters (flash lights) and Code 60" flag/board will incur penalties pursuant to Art. 6.

Art. 9

Division of vehicle categories A, B and C for the DMSB Permit Nordschleife

Category A		
All the classes and series that are not listed in Category B or C		
Category B		
Class/Series	Displacement	Specification/Notes
SP1	up to 1.4 l	NLS-/ 24h-Specials (acc. 24h)
SP2	1.62 – 1.75 l	NLS -/ 24h-Specials (acc. 24h)
SP3	1.75 – 2.0 l	NLS -/ 24h-Specials (acc. 24h)
SP4	2.0 – 2.5 l	NLS -/ 24h-Specials (acc. 24h)
SP Hybrid	up to 3.0 l TL	NLS- / 24h-Specials with hybrid drive (>4,2 kg/HP power Internal combustion engine)
SP Elektro	N/A	NLS- / 24h-Specials with electric motor (>5,71 kg/KW system power)
Cup 3	3.8 l	NLS -/ 24h- Cayman GT4 Trophy (>4.2 kg/ HP) (Porsche Endurance Trophy Nürburgring Cup 3)
Cup X	2.0 l	NLS - / 24h- KTM X-Bow Cup (>4,2 kg/ PS)
V1	up to 1.62 l	NLS / VLN production cars
V2	1.62-1.8 l	NLS / VLN production cars
V3	1.8-2.0 l	NLS / VLN production cars
V4	2.0-2.5 l	NLS / VLN production cars
V5	2.5-3.0 l	NLS / VLN production cars
V6	3.0 – 3.5 l	NLS / VLN production cars (>4.2 kg/HP)
VT1	up to 1.6l TL	NLS / VLN production cars with supercharging
VT2	1.6-2.0 l TL	NLS / VLN production cars with supercharging
VT3	up to 3.0 l TL	NLS / VLN production cars with supercharging
VT Hybrid	up to 3.0 l TL	NLS / VLN production cars with hybrid drive (>4,2 kg/HP power Internal combustion engine)
VT Elektro	N/A	NLS / VLN production cars with electric motor (>5,71 kg/KW system power)
H1 & H2	up to 2.0 l	Group H
AT/AT-G		Group AT incl. AT-G (alternative drive)
BMW M2 CS Racing Cup	3.0 l	NLS / 24h class BMW M2 CS Racing Cup (>4,2 kg/HP)
BMW M240i Racing	3.0 l TL	NLS / 24h class BMW M240i Racing
Opel Astra OPC	2.0 l TL	NLS class OPC

Category C	
RCN-race, Youngtimer Trophy, FHR-Series, races with historic cars	all classes acc. to the series or event regulations <u>Note:</u> Addition eligibility criteria may be published in the Series / Supplementary Event Regulations

Subject to changes

For further series or events on the Nürburgring Nordschleife, the corresponding conditions in the respective DMSB-approved supplementary series or event regulations will apply.

Note: Only the German and DMSB approved text of the Regulations will be binding.